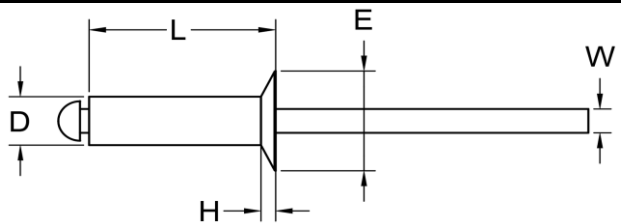

R	RIVET	Part Number Designation					
		RV-OSCH	-	3.0	-	6.0	-
Open End Blind Rivet Countersunk Head		Type	Dimension	Length	Material		
RV-OCSH							

Unit: mm

D	Grip Range (Min-Max)	Material		H	L +1/-0	E	W	Equivalent PN	Material	
		Body	Mandrel						Symbol	Stand for
3.0 +0.08 -0.15	1.0 - 3.5	Stainless Steel	Stainless Steel	1.0	6.0	5.4 - 6.3	2.10		SS	Stainless Steel
	3.5 - 5.0									
	5.0 - 7.0									
	7.0 - 9.0									
	9.0 - 11.0									
	9.0 - 12.5									
	12.0 - 14.5									
	13.0 - 16.5									
3.2 +0.08 -0.15	1.0 - 3.5	Stainless Steel	Stainless Steel	1.3	6.0	5.8 - 6.3	2.10			
	3.5 - 5.0									
	5.0 - 7.0									
	7.0 - 9.0									
	9.0 - 11.0									
	9.0 - 12.5									
	12.0 - 14.5									
	13.0 - 16.5									
15.0 - 21.5										
4.0 +0.08 -0.15	1.0 - 3.0	Stainless Steel	Stainless Steel	1.7	6.0	6.9 - 7.5	2.60			
	3.0 - 5.0									
	4.0 - 6.5									
	6.0 - 8.5									
	7.0 - 10.5									
	8.0 - 12.5									
	10.0 - 14.5									
	12.0 - 16.0									
	16.0 - 21.0									
	21.0 - 26.0									
	26.0 - 30.5									
	30.5 - 35.0									
4.8 +0.08 -0.15	1.0 - 2.5	Stainless Steel	Stainless Steel	2.0	6.0	8.3 - 9.5	3.10			
	2.5 - 4.0									
	4.0 - 6.0									
	6.0 - 8.0									
	8.0 - 10.0									
	9.0 - 12.0									
	10.0 - 14.0									
	12.0 - 16.0									
	16.0 - 21.0									
	21.0 - 25.0									
	25.0 - 30.0									
	30.0 - 35.0									
	35.0 - 40.0									
	40.0 - 45.0									